

The New Jersey Division of Parks and Forestry has total proprietary rights over the design documents referenced in this publication. Therefore, use of these materials by other organizations or consultants without the explicit approval of the New Jersey Division of Parks and Forestry is prohibited.

The USDA Forest Service hereby gives notice that the information herein contained shall not create any warranty, expressed or implied. The person or organization using this information waives and relinquishes any and all claims against the United States of America, its officers, employees, and project cooperators, for any loss, damage, personal injury, or death incidental to, or occurring as a consequence of, the use of it.

The use of trade, firm, or corporation names in this publication is for the information and convenience of the reader. Such use does not constitute official endorsement or approval by the U.S. Department of Agriculture of any product or service to the exclusion of others that may be suitable.

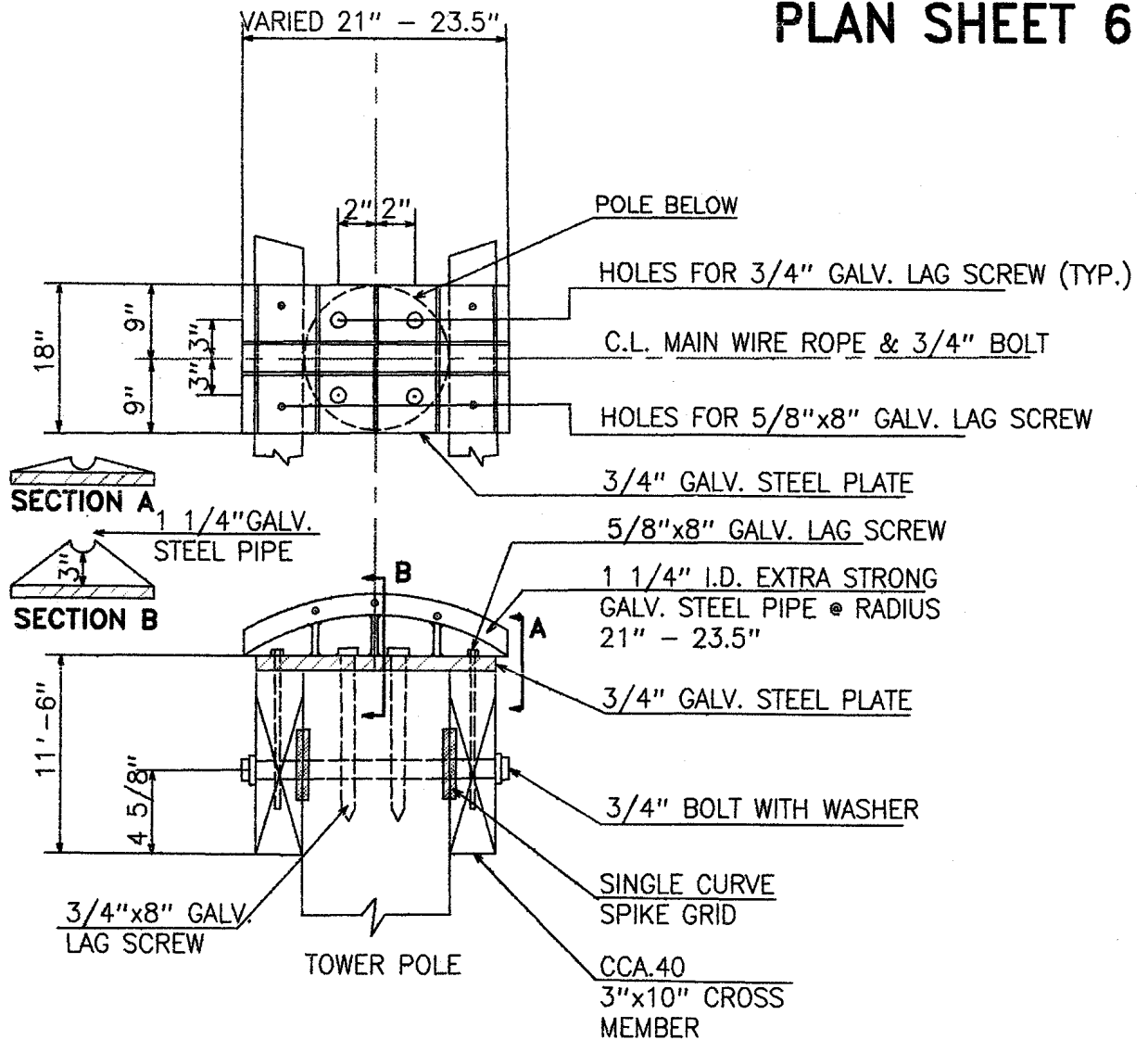

CABLE SADDLE DETAIL

NOT TO SCALE

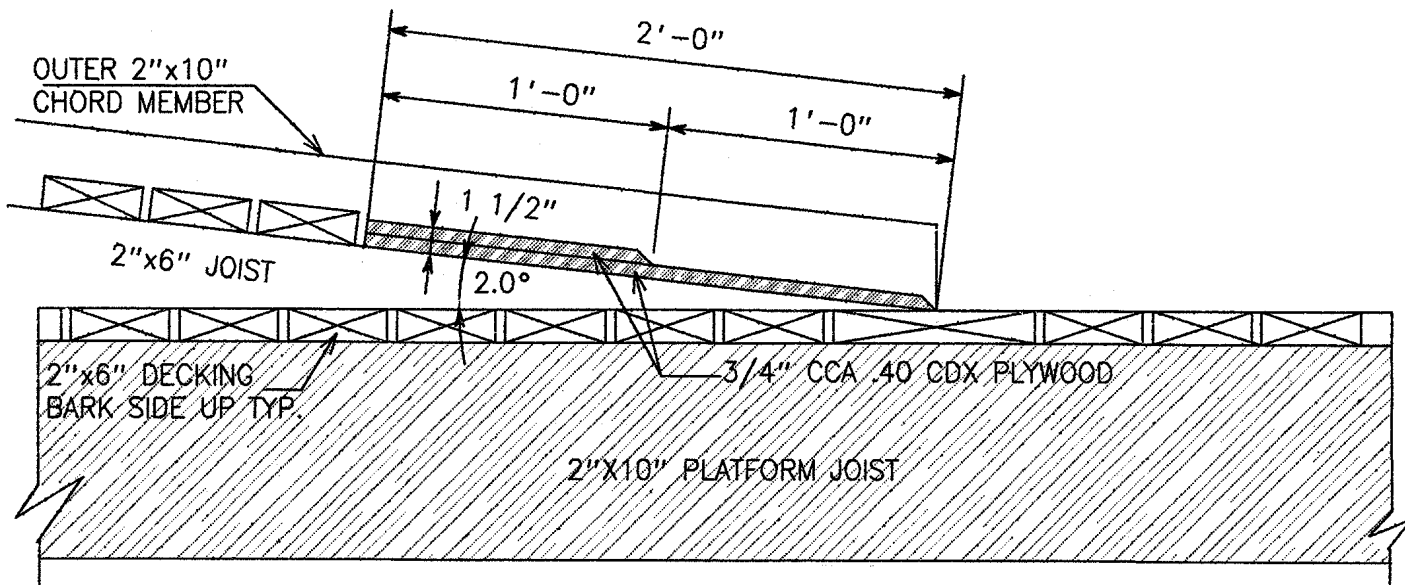

WALKWAY EDGE DETAIL

NOT TO SCALE